

# PRORIL

50 Hz

Rugged, reliable and cost effective, the Titan series pumps deliver excellent performance and serve a wide range of tough dewatering applications like mines, construction site, rental applications and other demanding industries.

**Dewatering Pump**

## **TITAN 8220**

Heavy Duty Dewatering Pump



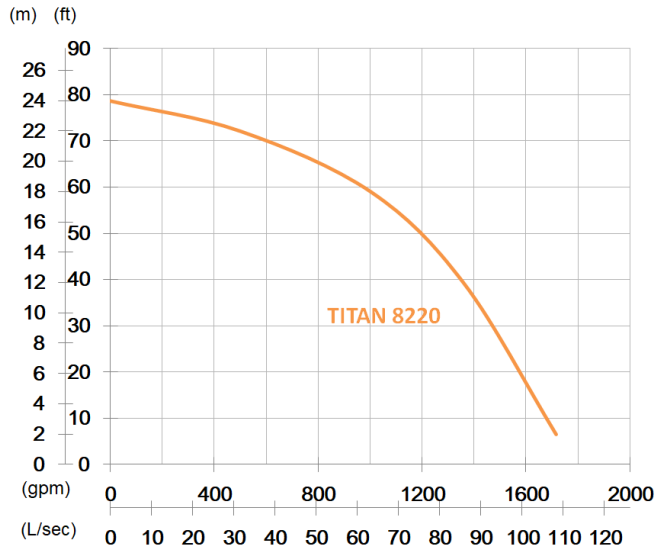

Shaft Speed : 1450 rpm

Outlet : 200mm, 8in

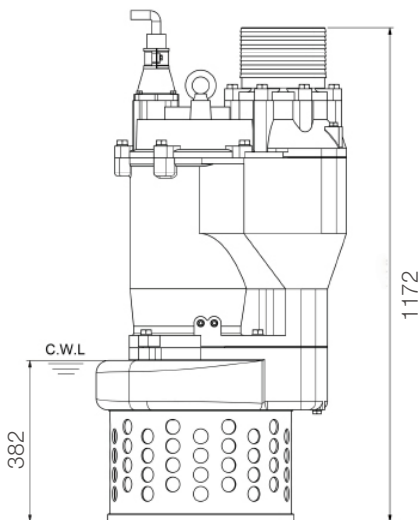
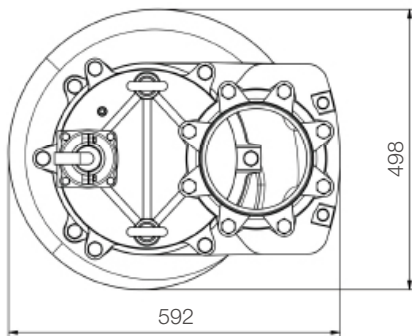

unit : mm

Weight : 360kg / 794 lbs

OUTPUT	HEAD	FLOW
22 kW	Rated : 18m, 59ft	Rated : 63.3 L/s, 1003 gpm
30 HP	Max : 24m, 79ft	Max : 108.3 L/s, 1716 gpm

Solid Passage : 35 mm, 1.4 in

Pump Type	Electric Submersible Pumps	
	3-Phase	
Motor	Type	Induction Motor
	Poles	4 Pole
	Insulation	Class F
	Protector	Circle Thermal Protector
	Starter	D.O.L.
Lubricant	Food Grade (ISO VG32)	
Impeller Type	Opened	
Shaft Seal	Double Mechanical Seal	
	Silicon Carbide VS Ceramic / Carbon	
Bearings	C3 Shielded ball bearings	
Cable	PVC (CSA Certified) / H07BQ-F	
	10m (33ft) or longer upon request.	
Materials	Pump Casing	Ductile Iron
	Impeller	Chromium Iron
	Motor Frame	Gray Iron
	Motor Shaft	Stainless Steel
	Strainer	Carbon Steel
Max. Liquid Temperature	40°C (104°F)	
Max. Submersion Depth	20m (66ft)	
pH Range	pH 5 - pH 8	